

Integrated Li-Fi system for a control plant

Sistema Li-Fi integrado para una planta de control

MARTÍNEZ GUASHIMA, Oswaldo G.¹
GUANGA CHUNATA, Deysi M.²
MENA REINOSO, Ángel P.³
DE LA CRUZ FERNÁNDEZ, Gabriela M.⁴

Abstract

The document presents the development and implementation of a data transmission system developed with Li-Fi technology to monitor variables of a laboratory plant. The acquisition and processing data were monitored on the web, which was programmed in LabView2018; the variables studied were speed and temperature. Tests on the algorithms were performed using the criteria of integral of the absolute error. It was possible to determine that Li-Fi has a lower latency time than Wi-Fi, what directly influences in the ITAE of the processes.

Key words: telecommunications network, Li-Fi, data transmission, telematics.

Resumen

El documento presenta el desarrollo e implementación de un sistema de transmisión de datos desarrollado con tecnología Li-Fi para monitorear variables de una planta de laboratorio. Los datos de adquisición y procesamiento fueron monitoreados en la web, que fue programada en LabView2018; las variables estudiadas son la velocidad y la temperatura. Las pruebas sobre los algoritmos se realizaron utilizando los criterios de integral del error absoluto. Fue posible determinar que Li-Fi tiene un tiempo de latencia más bajo que Wi-Fi, lo que influye directamente en el ITAE de los procesos.

Palabras clave: red de telecomunicaciones, Li-Fi, transmisión de datos, telemática.

1. Introduction

More than a half million devices are added per year to data transmission networks through wireless communication networks, which are limited mainly due to their bandwidth. New technologies are designed and tested to replace the communication needs that will be demanded in a few years. This new technology aims to be the communications revolution (Moreno, 2018). On the other hand, the visible spectrum of light offers a higher frequency bandwidth, so some technologies use the visible light as a mean of communication; one of these technologies is the so-called Li-Fi (Light Fidelity). This technology is wireless and bidirectional, with multi-

¹ Master University Technology System and Networking Communication, Facultad de Informática y Electrónica, Carrera de Telecomunicaciones. Escuela Superior Politécnica de Chimborazo. e-mail: omartinez@epoch.edu.ec

² Magister in Basic Mathematic, Facultad de Informática y Electrónica, Telecomunicaciones. Escuela Superior Politécnica de Chimborazo. e-mail: deysi.guanga@epoch.edu.ec

³ Magister in Basic Mathematic, Facultad de Informática y Electrónica, Carrera de Electrónica y Automatización. Escuela Superior Politécnica de Chimborazo. e-mail: angel.mena@epoch.edu.ec

⁴ Linguistic competences at National University of Chimborazo. e-mail: gmdelacruz@unach.edu.ec

user characteristics and its degree of electromagnetic pollution is practically non-existent. Therefore, Li-Fi is a potential candidate for communication applications between devices. The flexibility of wireless networks allows us to establish advantages such as hardware size and robustness toward external disturbances (Espinosa & Vivanco, 2017).

1.1. Related Studies

United Kingdom has carried out amount of research about Li-Fi; in Latin America, there are no researches in this regard. Haas, Yin Wang & Chen (2015) established an analysis of communication based on visible light, considers that Li-Fi is an application superior to VLC, its use is focused on doing wireless systems completely connected to the network; it can also be used in IoT systems. Swami (2015) concludes that Li-Fi achieves transmission and reception of data and can be cheaper due to the large number of light bulbs deployed inside buildings. Hase, Bhanushali, Vora, Goswami & Kerawalla (2009) conduct an empirical investigation on the random orientation based on Laplace that a random user can follow to evaluate the performance of the system. It is not identified jobs that relate the control of industrial processes with Li-Fi as a means of communication for data transmission in a bidirectional way. The previous mentioned studies handle general terms:

Wireless networks. Wireless networks are more practical for users and allow the development of new products and services, nowadays a variety of technologies are developed to implement point-to-point and multipoint links, this concept includes Li-Fi. Wi-Fi is, today, the most used technology based on the number of devices that use it to connect to the Internet. The IEEE 802.11a, 802.11b, 802.11g and 802.11n wireless standards are all known as Wi-Fi technologies.

Viloria Núñez, Cardona Peña y Lozano Garzón (2009) indicate that communication by visible light. If you talk about communication by visible light or VLC, it references to a lighting source such as a light emitting diode or LED that is also capable of transmitting information, which means that VLC is both lighting and communication. All this is feasible thanks to its high data transmission speed. VLC is a short-range technology due to the light propagation distance emitted by LED, the visible light spectrum it is modulated to transmit information. As can be seen in Figure 1, shows the electromagnetic spectrum that is the frequency range of electromagnetic radiation and their respective wavelengths and photon energies. It covers electromagnetic waves with frequencies ranging from 10^7 Hz, corresponding to wavelengths from tens of meters to a fraction of the size of an atomic nucleus. Moreover, the electromagnetic spectrum of visible light covers between 350 nm and 800 nm wavelength and the frequencies are between 400 THz and 700 THz (Ndjiongue, Ferreira, & Ngatched, 1999).

Figure 1
Electromagnetic Spectrum, <https://www.scienceinschool.org>

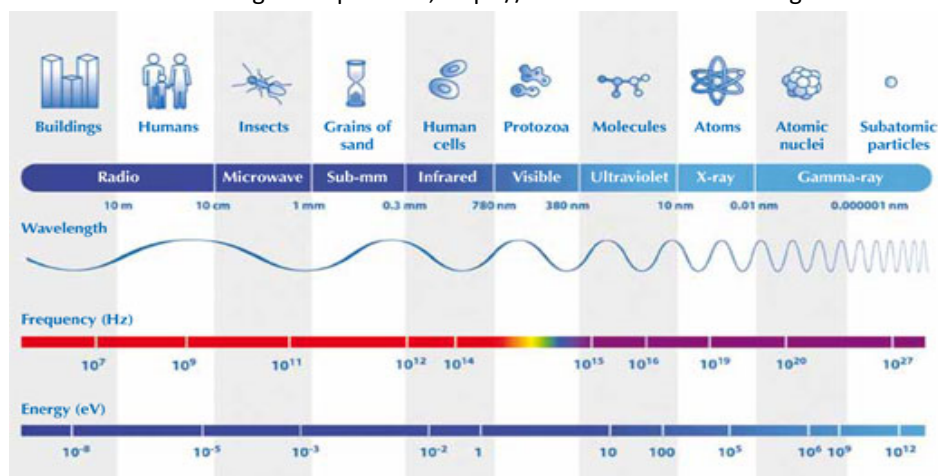

Light Fidelity: Li-Fi is found as a part of the IEEE 802.15.7 standard, which is an application of visible light communications (VLC), which means that it uses the spectrum of visible light to transmit data. Its capacity is 10,000 times bigger than what is currently available in the radio spectrum; one of the advantages of this technology is that the actuators as light emitters can be installed indoors. Li-Fi takes advantage of the switching frequency of the LEDs which is very high; this is another advantage that is managed to transmit data in binary format (Arellano García, n.d.).

In this way, the study intends to relate process control with Li-Fi as a means of communication for data transmission in a bidirectional way.

2. Methodology

The design and execution of the experiment was carried out in a laboratory control plant, one of the reasons for choosing this work scenario was due to the viability and availability of the equipment.

For the data transmission study, a comparative analysis of an LI-FI network versus a WIFI network was used. Communication based on the 802.11.n protocol contributed to the validation of results due to its belonging and performance at the same OSI layer. For the experimental development of the research, the flow chart scheme of Figure 2 was followed. Finally, a Wi-Fi of the 802.11n point-to-point communication standard was used, in this configuration only one XC station was implemented, due to the cost

Figure 2
Flowchart of the applied methodology

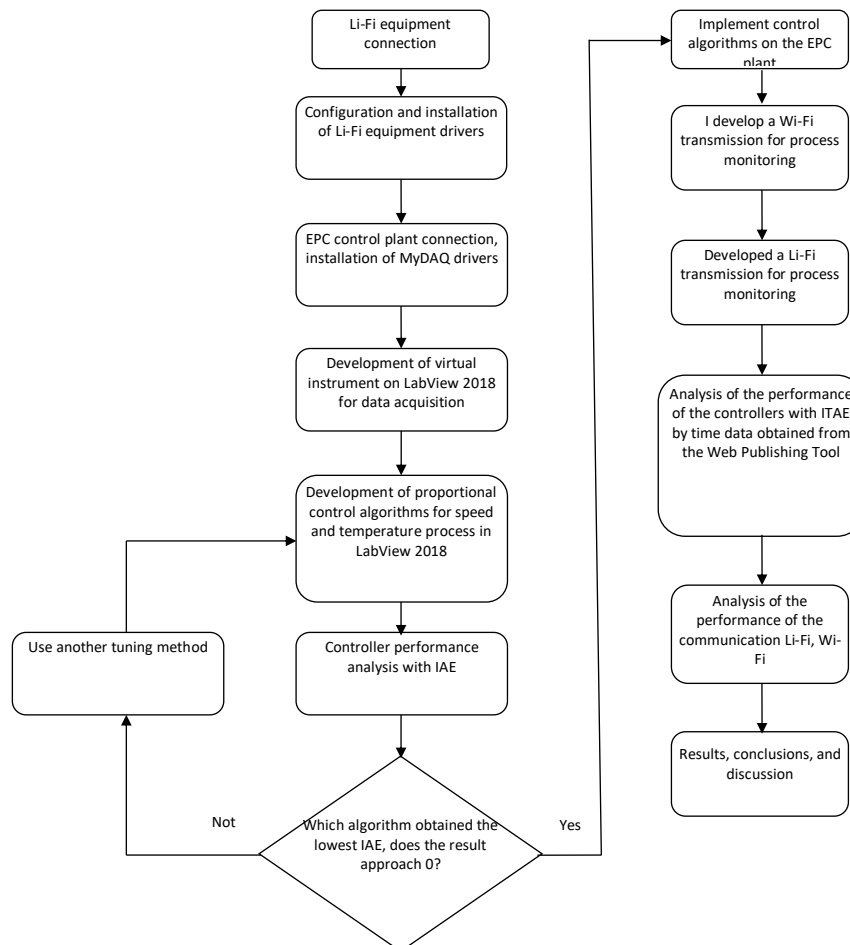

The first step to configure the general architecture of the system was the acquisition of data generated by the EPC plant, for this aim the National Instruments[®] MyDAQ data acquisition card was used, which facilitated communication to the PC through the serial port. Once the information was registered on the PC, the next step consisted of publishing data on the internet through transmitter modules, then the information was processed and analyzed using a virtual instrument. Finally, the values of the variables of the process could be visualized and monitored wherever through a web page for later evaluation. This procedure is shown in figure 3.

Figure 3
General System Architecture

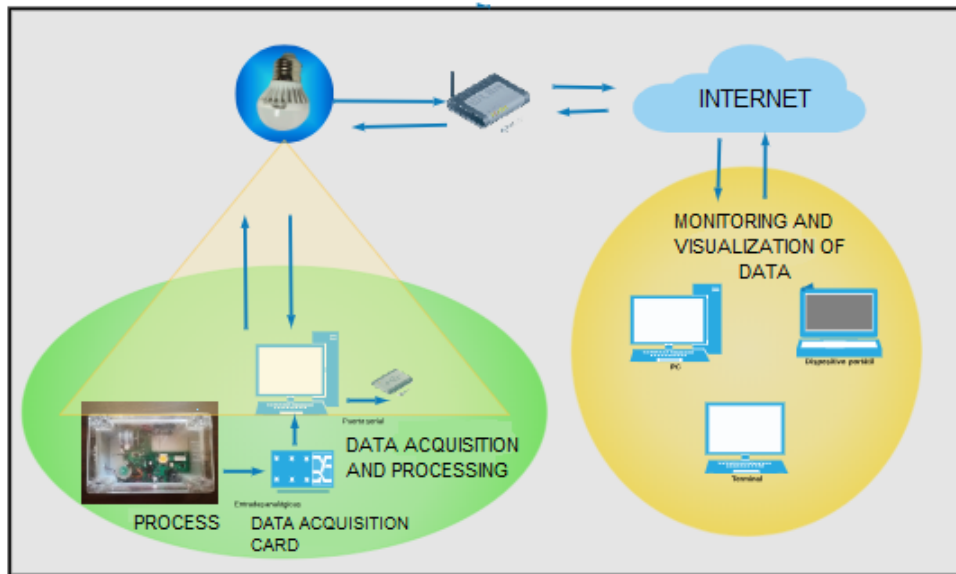

2.1. Connection and configuration of Li-Fi equipment Subchapter

For the configuration of the Li-Fi equipment, LabView 2018 will be seen in the data acquisition. Likewise, proportional algorithms for speed and temperature control were developed, thus examining the performance and analysis of the IAE (Absolute Integral Error).

For the acquisition, implementation and configuration of Li-Fi equipment, the collaboration of Only two companies worldwide that have the ability to provide Li-Fi devices to research institutes was required, one of them being PURE Li -Fi, which offers various communication devices and actuators (lamps), as shown in figure 3.

The main characteristics of the equipment used according to the manufacturer were:

- The Li-Fi system connected to the network provides end-to-end IPv4 and IPv6 connectivity.
- Full duplex wireless link that provides 43 Mbps for both upload and download.
- Minimum operating distance 60 cm.
- Maximum operating distance 6 m.
- Access point supports up to 8 stations.
- Large number of LED luminaire actuators.
- Supports DALI, 0-10 V and CoAP.

Figure 4
Connection Li-Fi devices (Li-Fi assembly)



The following steps were applied to install the Li-Fi equipment:

- a. The file install.exe was run as administrator
- b. Li-Fi-XC USB was installed through the instructions window by pressing next
- c. Finally, it was pressed finish Li-Fi-XC USB installer.

Once the installation of the controller was completed and the Li-Fi-XC was connected, it created a network in the computer similar to the Wi-Fi network. It is shown in Figure 5.

Figure 5
Li-Fi network detection

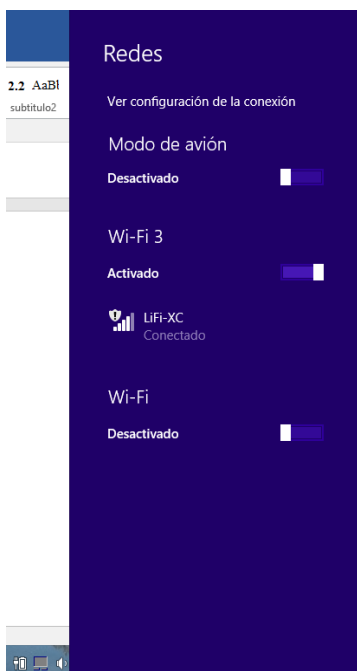

For mounting the Li-Fi devices a flat surface was required in which two holes were made, one with a diameter of 65 mm for the access point and the second of 182 mm for the LED lamp. The applied separation distance between the holes was maximum 20 cm measured from the center. Figure 6 shows the general assembly of the equipment for which a cubicle was constructed.

Figure 6
Installation Li-Fi modules

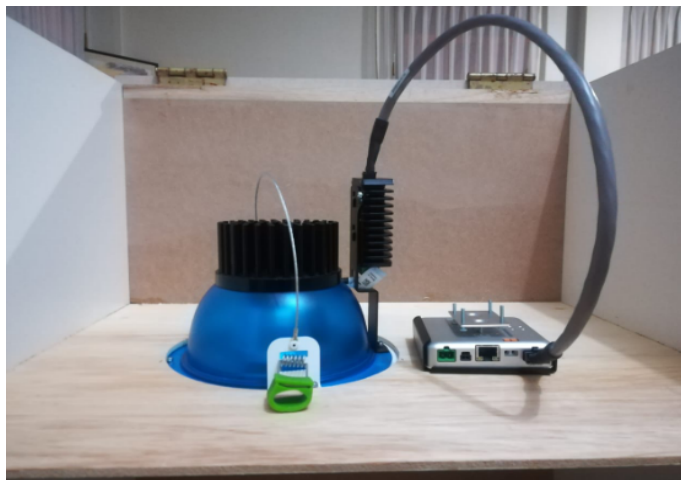

2.2. Connection and configuration of the EPC plant

The control algorithms were implemented in a laboratory environment developed by the manufacturer Data Lights®, as it is shown in figure 7. This laboratory allowed the control of the experimental processes considering the variables of temperature, speed, position and signal treatment from CA. The system provided the experiment with the necessary instruments for the generation and acquisition of data with a microcontroller-based card. For this, the MyDAQ card that had 8 digital I / O, 3 analog inputs and 2 pure analog outputs was used, its resolution at its analog input is of 16 bits, the sampling rate was of 200 KS / s (kilo samples per second).

Figure 7
EPC and MyDAQ, Laboratory scenery for speed and thermal processes



Also, it can configure digital inputs and outputs whose switching frequency was high for monitoring optical decoders (encoders), provoking modulation signals by pulse width (PWM).

Figure 7 shows how the comparison between two processes was established, the first with high dynamics in which the actuator was a CC motor whose speed range was from 0 to 4000 rpm; the other, was a process with slow dynamics such as a thermal whose operating range ranges from 0 ° C to 80 ° C; in this case the actuator was a LED that increases its temperature depending on time.

The time of establishment of the controlled variable was an important fact that must be considered; therefore, it was desired to validate the communication with two different processes in its dynamics.

Virtual instrument of speed: figure 8 shows the development of the virtual instrument of the speed process. It consists on a while loop in which the icons of the NI DAQmx and Control and Design Simulation were located for the acquisition and control of the plant data, which ones were obtained by the encoder in an analogical way processing by the Tone Measurements icon, the objective was to achieve its frequency and its amplitude.

If the amplitude was less than 1, it means that the DC motor did not rotate, therefore, the encoder did not deliver a pulseless signal, the frequency was then an indirect variable that was used to measure the variable speed.

Figure 8
Speed control block diagram

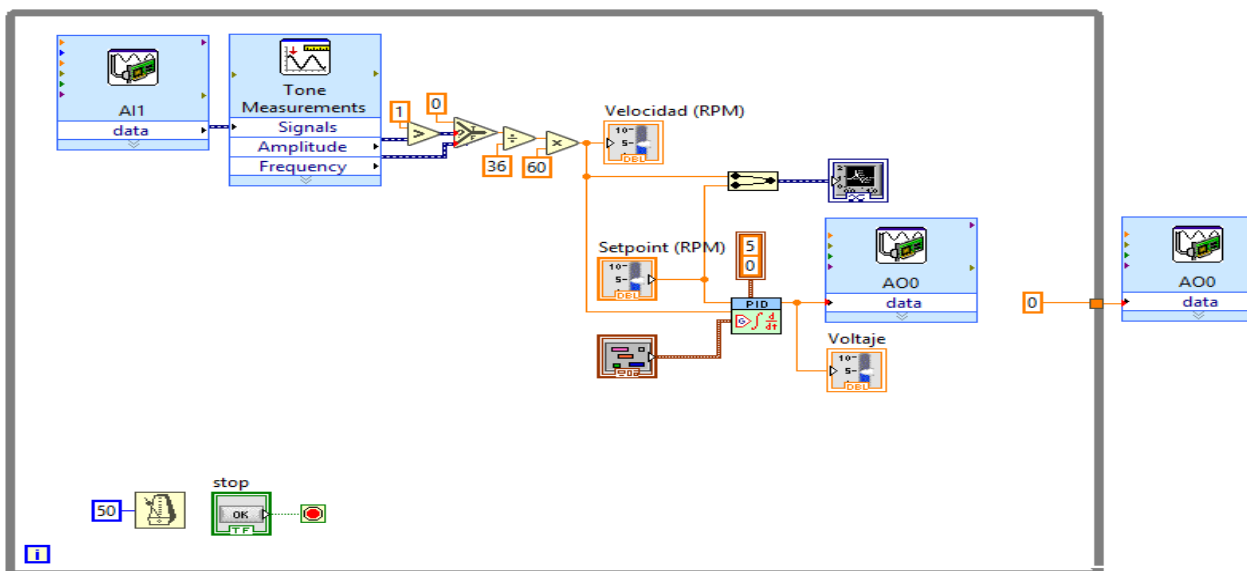

To evaluate the communication, the following test protocol was performed:

1. Run the controller VI.
2. Open the Wireshark program and capture data traffic.
3. Monitor the controller on the website.
4. Vary the setpoint of the controller.
5. Introduce disturbances to the control plant.
6. Stop capturing traffic with Wireshark.
7. Save the file in format (.pcapng).
8. Open the Steelcentral Packet Analyzer program and import the file
9. Generate a report which will display the time, packets and bits transmitted.

Virtual thermal instrument: For the control of the thermal process, the control algorithm of type PI was applied with a setpoint of 60 ° C, to do that, the process was divided into two while loop. The first was related to the acquisition of data as can be seen in figure 9, in the second a proportional type control was developed whose thermal actuator was the LED and, a control type on / off to the plant fan, also it contained the programming necessary to increase the temperature proportionally. Its configuration can be seen in figure 10 that uses a PWM signal to proportionally turn on the actuator. With the PI type control algorithm, the performance was validating using the ITAE method.

Figure 9
Data acquisition loop and thermal process controller

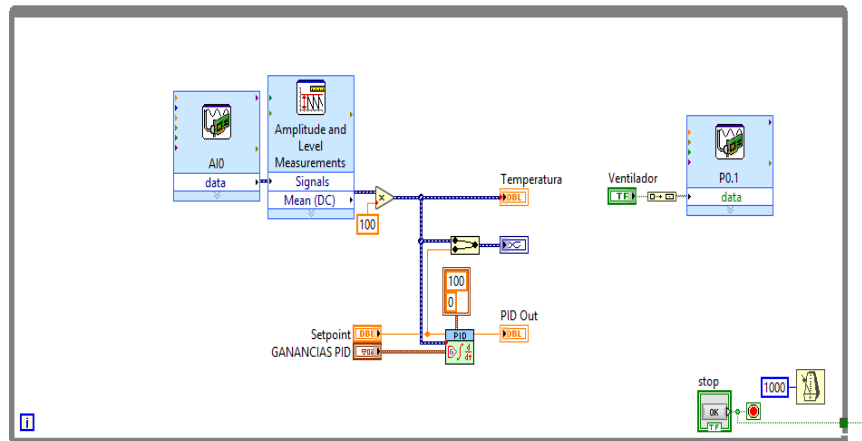
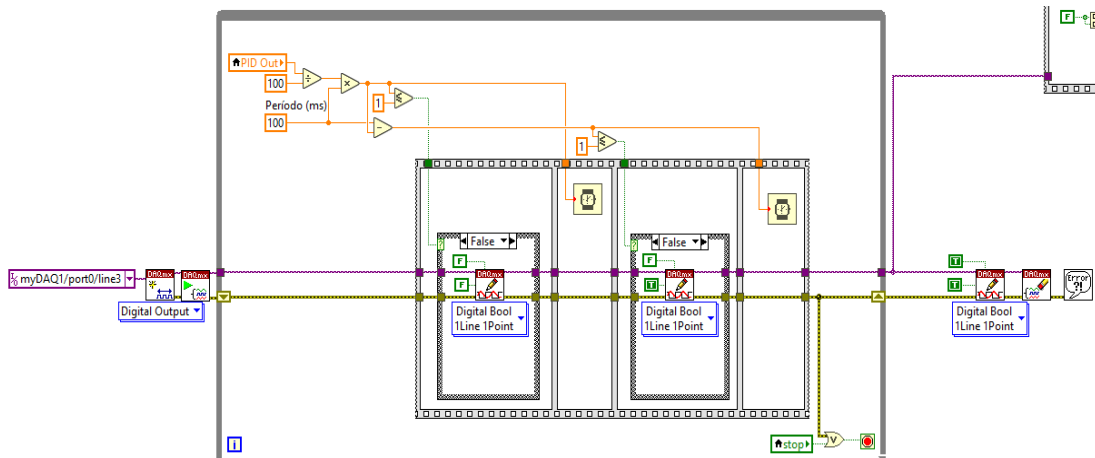

Figure 10
PWM signal generation loop



3. Results

3.1. Development of control algorithms

The values of the controller parameters that were obtained through the control algorithm with the Ziegler-Nichols method produced the speed results shown in figure 11. These data allow calculating the period and determining the constants Kcr, Fcr and Pcr detailed in table 1.

Figure 11
Oscillating signal to obtain the period from the speed

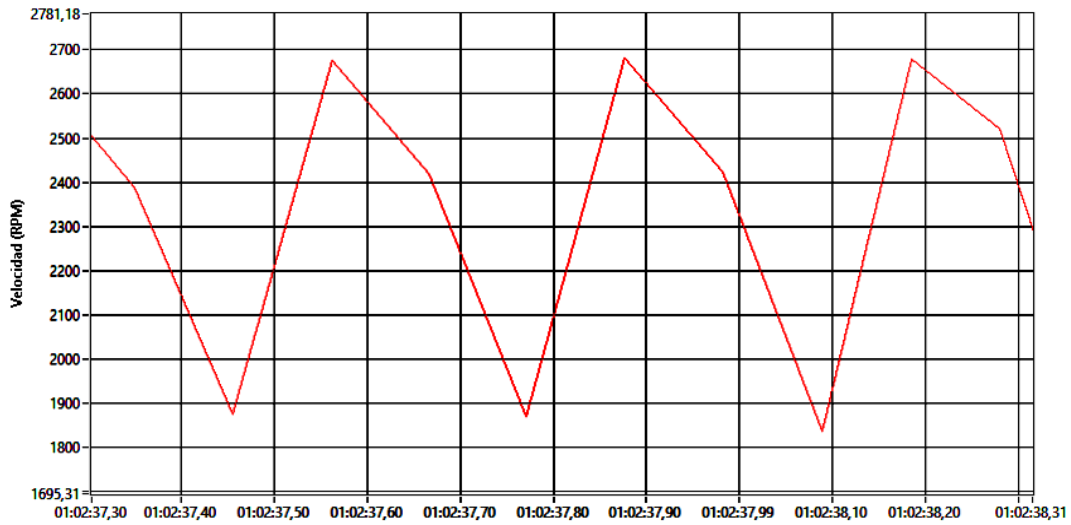

Table 1
KCR, FCR and PCR values used
in speed process tuning

Parameter	Value	Unit
Kcr	0.00270	-----
Fcr	3.15	Hz
Pcr	0.3467	s

After applying the first Ziegler-Nichols rule method, the proportional controller generates the results of the graph provided in figure 12. These data allow to represent the response to a stimulus of the unit step type. The curve generated is S-shaped and it is characterized by delay time L and time constant T, a tangent line at the point of inflection of the curve and the intersections of the line with the time axis and the temperature axis are determined as shown in figure 12 and the parameters obtained experimentally are detailed in the table 2.

Figure 12
Thermal system response

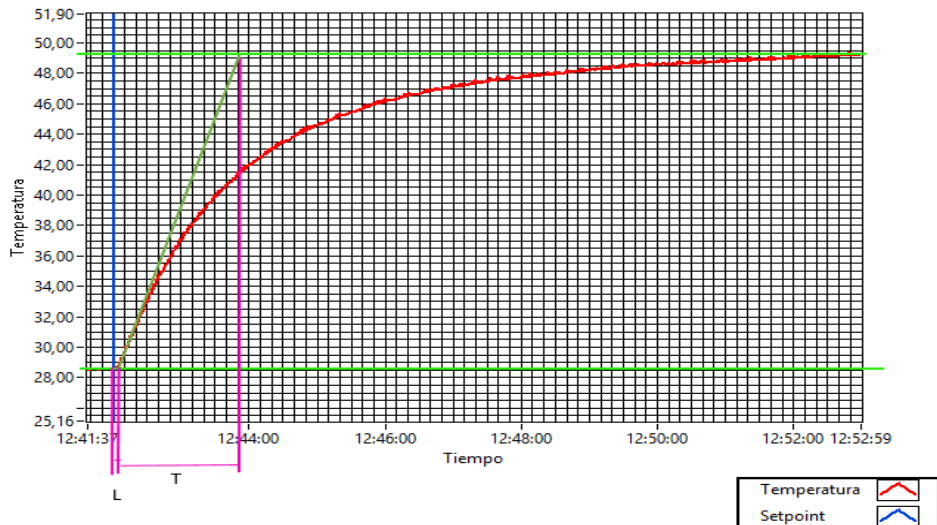

Table 2
Values obtained with the second Z&N method

Controller	KC	TI(S)	TI(MIN)	KI(S)	KD(MIN)
P	0.00135	Inf	Inf	0	0
PI	0.00121	0.26391	0.004398	0	0
PID	0.00162	0.15835	0.002639	0.03958	0.0006598

The three controllers are implemented with the data obtained from the tuning procedures, as a final result the parameters expressed in Table 3 are obtained, these controllers are subject to validation.

Table 3
Thermal process controller parameters

Controller type	Kc	Ti(s)	Ti(min)	Td(s)	Td(min)
P	21	inf	inf	0	0
PI	18.9	16.66	0.2778	0	0
PID	25.2	10	0.1667	2.5	0.0417

3.2. Controller performance analysis

Speed controller

The controller was tuned to the parameters calculated and shown in Table 1. Three set points were tested with the values 2000, 2500 and 3000 rpm; the IAE was calculated and a similar procedure is applied in the algorithm for the thermal process. For that, equation 1 is handled, where e(t) is equal to the set point minus the present value:

$$IAE = \int_0^{\infty} |e(t)| dt \quad (1)$$

Figure 13
IAE of the PI and PID speed controllers

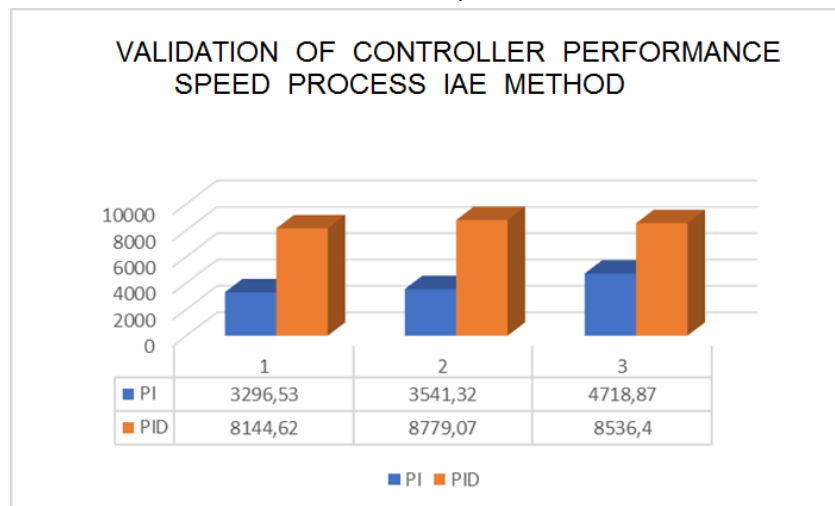
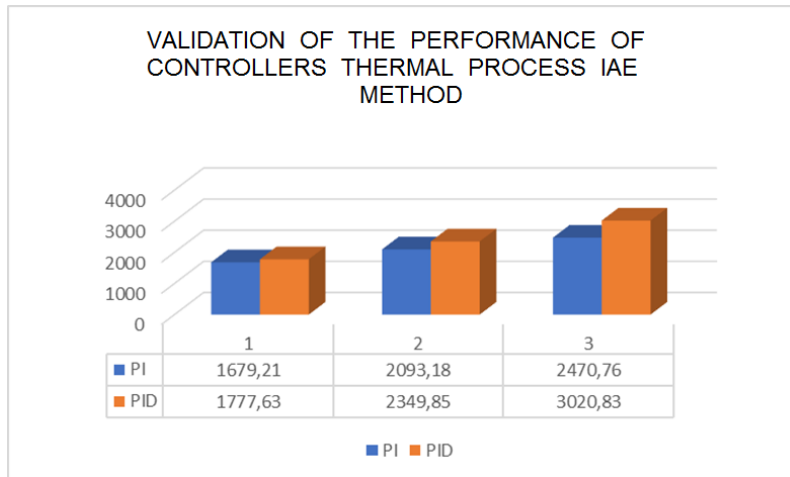

Figure 14
IAE of the PI and PID temperature controllers with different set point



In both cases, both the velocity and the temperature, the final value of the IAE obtained is analyzed in order to determine the most efficient control algorithm in steady state, both for the speed and thermal process the algorithm of the type PI is the that lower IAE achieves in validations.

3.2. Wireless transmission

Once the best control algorithm has been determined, it is desired to validate its effectiveness through Li-Fi communication. It is contrasted with a Wi-Fi communication based on the 802.11.n protocol, because these days it is the most used and it is found in the same layer of the OSI model. It is important to examine the latency of wireless communication since it is the analysis link between the link and the controlled processes, for this the controller efficiency analysis method called ITAE (Integral of absolute error by time) is used, whose calculation is done with equation 2.

$$ITAE = \int_0^{\infty} t |e(t)| dt \tag{2}$$

Speed process

Figure 15 shows the response of the plant for the speed process with the PI controller and the setpoint of 2000 rpm, observing the figure determines the time it takes for the system to reach the set setpoint of 1 s.

Figure 15
PI controller response with a 2000 rpm setpoint

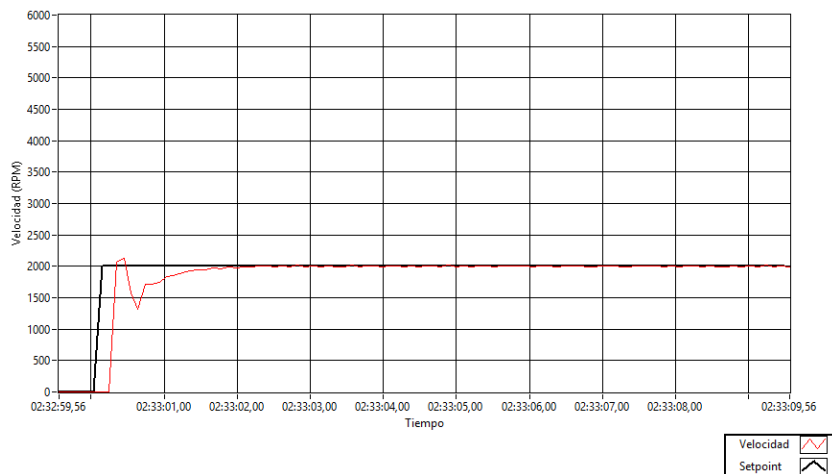

Through the Web Publishing Tool[®], the results of the wireless communication were compiled, both for Li-Fi and for Wi-Fi of the process, the results can be seen in Table 4, in addition it can be distinguished graphically in Figure 16 the difference of the value of ITAE for the two links.

Table 4
Results evaluated with the ITAE evaluation

Setpoint	ITAE Li-Fi	ITAE Wi-Fi
PI/SP= 2000 rpm	3296.53	30308.04
PI/SP= 2500 rpm	3541.32	31126.96
PI/SP= 3000 rpm	4718.87	34272.25

Figure 16
Li-Fi and Wi-Fi communication speed process ITAE

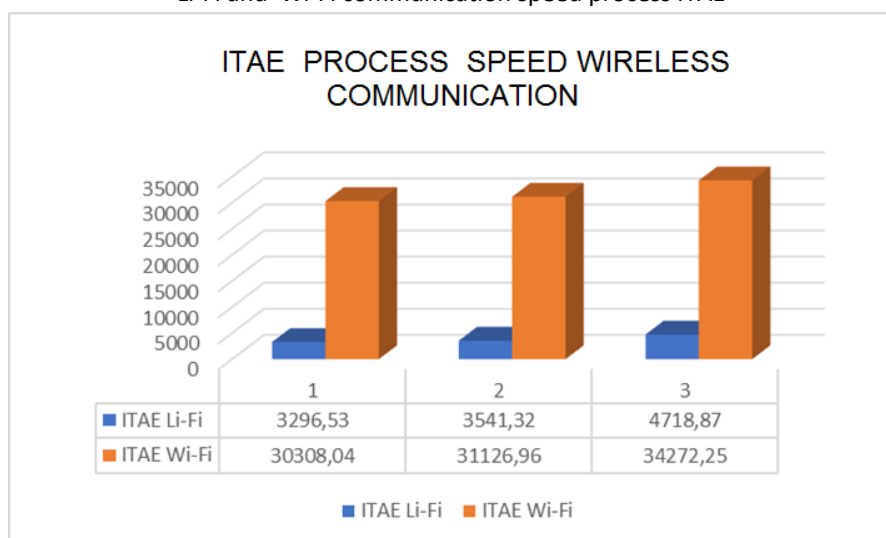

Thermal process

The result obtained for the performance of the algorithm has been evaluated with a setpoint of 60 °C is presented, the system response can be seen in figure 17. The results of the ITAE collected through Web Publishing Tool are shown in table V.

Figure 17
60 °C set point thermal process PI controller response

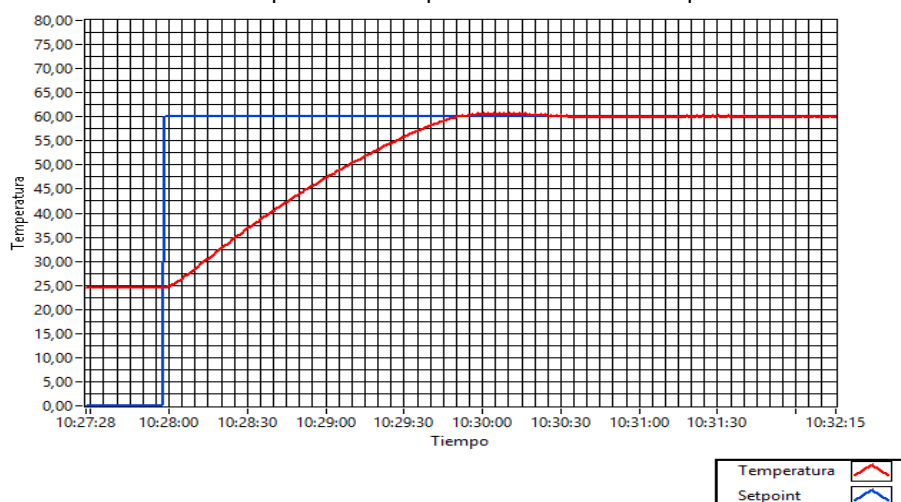
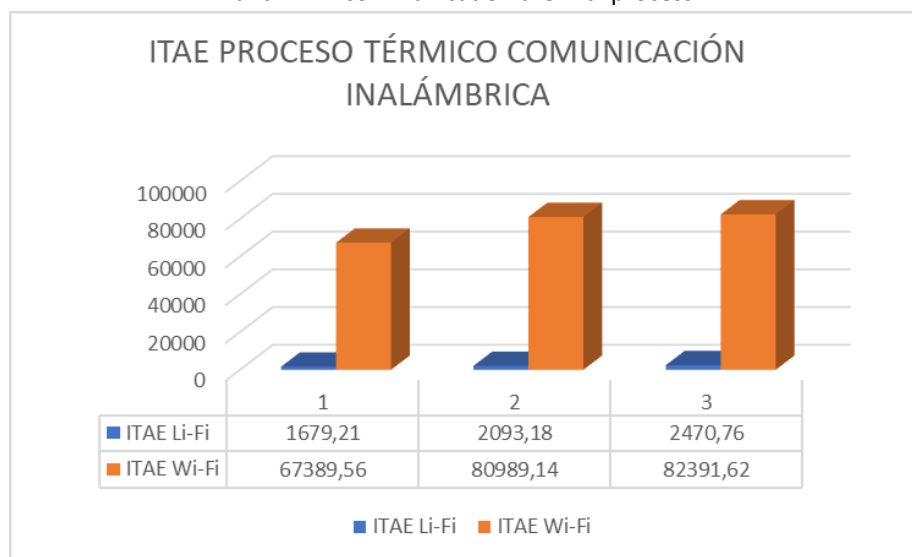

Table 5
Temperature control evaluation results

CTRL/SP	ITAE Li-Fi	ITAE Wi-Fi
PI/SP=60 °C	1679.21	67389.56
PI/SP=65 °C	2093.18	80989.56
PI/SP=70 °C	2470.76	82391.62

Figure 18
Li-Fi and Wi-Fi communication thermal process ITAE



3.3. Wireless transmission

To compare the results on the number of bits characterized for Li-Fi and WiFi, a comparative table has been organized, shown in Table 6

Table 6
Wireless communication Li-Fi and Wi-Fi speed process

Name	Li-Fi	Wi-Fi
Total number of bits	49488	102176
Total number of bytes	6186	12772
Total number of packages	52	102
Number of IP bytes	5394	10452
TCP number bytes	3856	1102
UDP number bytes	1538	9078

Completing the protocolo of tests, it is obtained the results shown in Figures 19 and 20. In this case, the set point was modified from the server with the values of 2000, 2500, 3000 rpm, while a single one was modified from the client. instead varying the speed from 3000 rpm to 2000 rpm. The test lasted 120 seconds.

Figure 19
 Bits per second and packets transmitted with Li-Fi process speed

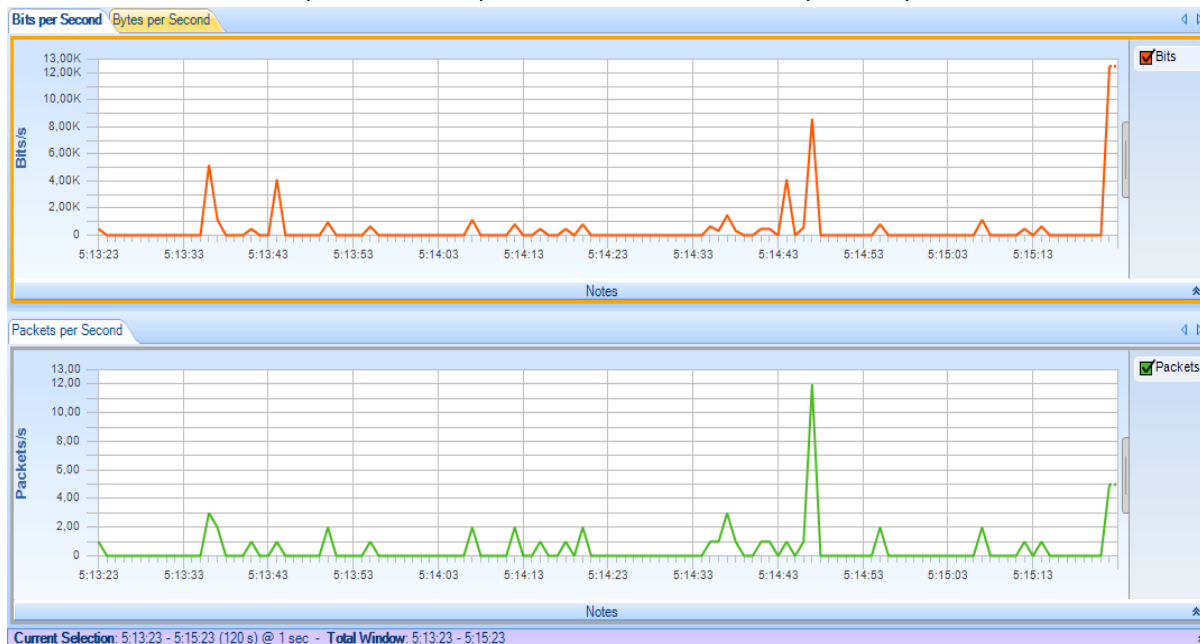
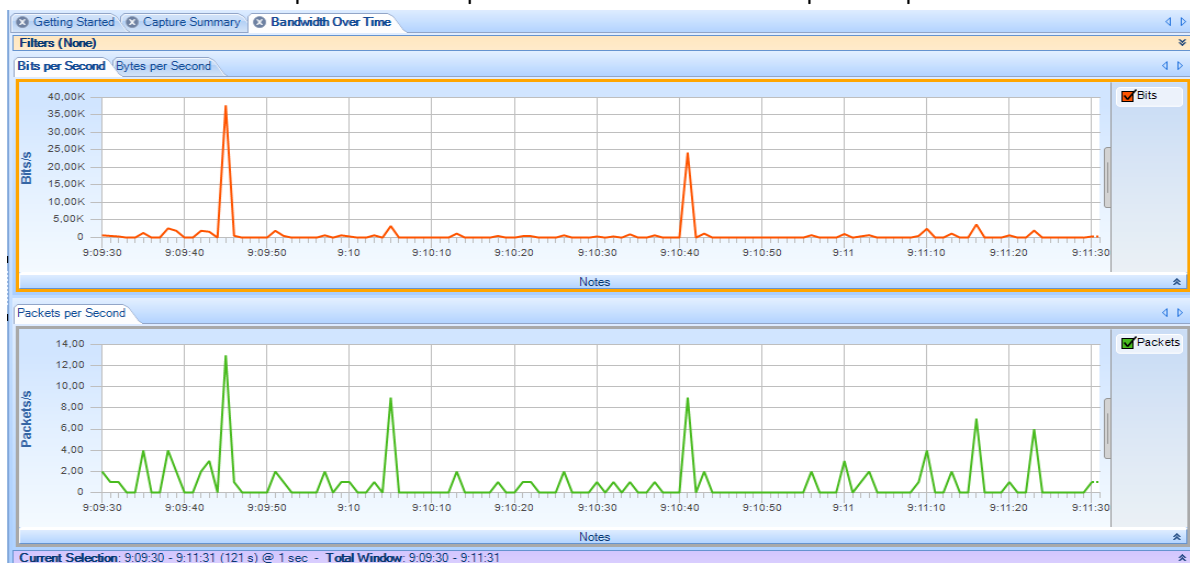

Figure 20
 Bits per second and packets transmitted with Wi-Fi process speed



Thermal process

The results of the wireless communication are observed in figures 21 and 22 and are also expressed in Table 7; their duration was 854 seconds.

Table 7
Li-Fi communication results for temperature control

Nombre	Li-Fi	Wi-Fi
Total number of bits	824576	1286584
Total number of bytes	103072	160823
Total number of packages	528	813
Number of IP bytes	92272	145503
TCP number bytes	75268	45380
UDP number bytes	17004	98213

Figure 21
Bits per second and packets transmitted Li-Fi of the temperature controller

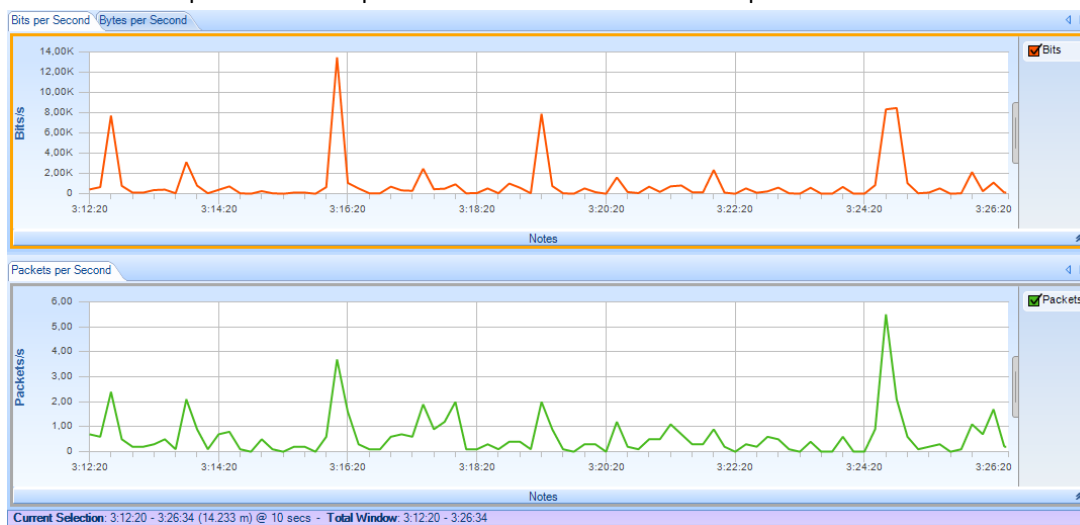

The condensation of general comparative data of the communications applied to the processes is presented in Tables 8 and 9; the main values to be taken into account are the transmission speed and its latency.

Figure 22
Bits per second and packets transmitted with Wi-Fi temperature controller

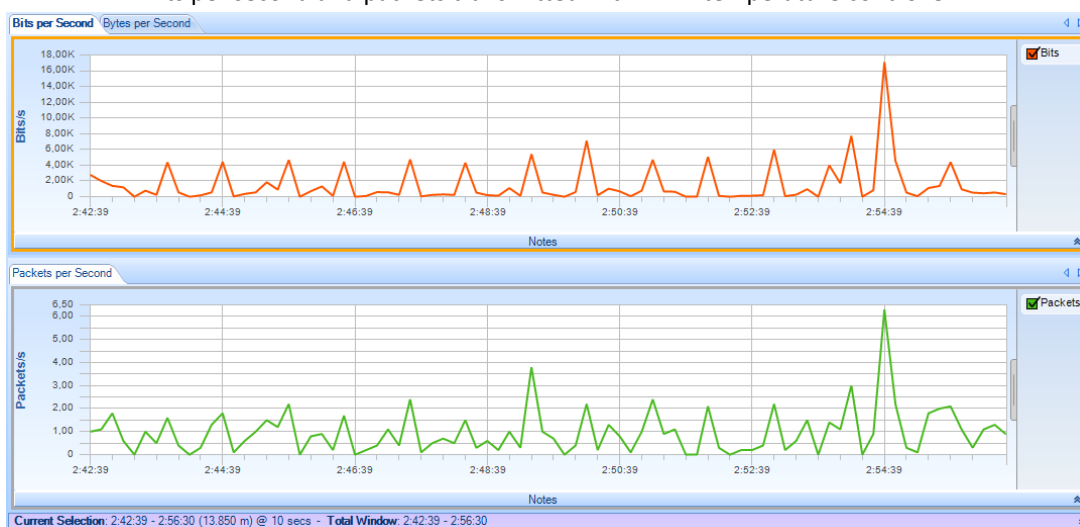

Table 8
Comparative results of speed control communication

Communication	Packages	Bit sent	Speed	Latency
Li-Fi	52	49488	43 Mbps	1,15 ms
WIFI	102	102176	22 Mbps	4,64 ms

Table 9
Comparative results of temperature control communication

Communication	Packages	Bit sent	Speed	Latency
Li-Fi	528	824576	43 Mbps	0.01917 ms
WIFI	813	1286584	22 Mbps	0.05848 ms

4. Conclusions

The findings of this study reveal that the characteristics of Li-Fi equipment, installed under parameters established by the manufacturer, allowed the development of a data transmission system for a process control system that obtained a higher transmission speed, a lower number of packets and a shorter latency time in the transmission which directly influences the ITAE parameter as seen in tables 8 and 9.

This investigation was limited to the environment in which their tests were carried out, their luminaire provided the maximum amount of lumens allowed, the following work is started considering introducing light disturbances, such as those that may arise in an industrial plant, in order to attenuate or increase the amount of lumens provided by the LuciCup Li-Fi actuator, which implies designing a controller that allows obtaining the least amount of information loss based on the amount of lumens emitted by the actuator.

Under ideal conditions, Li-Fi communication allows us to develop monitoring and control of processes with varied dynamics. The ITAE validation method is effective for relating the steady-state error of the controller and the latency in communications for validation. However, the operation of Li-Fi is limited to the environment in which it is applied so it is considered a complement to Wi-Fi technology to obtain efficient wireless communication.

Acknowledgements

Thanks to the research institute of Escuela Superior Politécnica de Chimborazo.

Bibliographic references

- Arellano García, R. (n.d.). Li-Fi: El futuro de las comunicaciones vlc.
- Espinosa, M., & Vivanco, M. (2017). Li-Fi: Velocidad de internet sorprendente bajo la luz visible. *Killkana Técnica*, 1(2), 1-6.
- Haas, H., Yin, L., Wang, Y., & Chen, C. (2015). What is LiFi? *Journal of lightware technology*, 34(6), 1533-1544.
- Hase, M., Bhanushali, P., Vora, P., Goswami, P., & Kerawalla, M.A.K. (2009). Li-Fi-a revolution in the field of wireless-communication. *International Journal of Advanced Research in Engineering and Applied Sciences (IJAREAS)*, 5(4), 10-23.

- Moreno Iza, G. P. (2018). Prototipo de comunicación vía luz Li-Fi, para la transmisión de datos mediante un web service. B.S. thesis, Latacunga: Universidad Técnica de Cotopaxi; Facultad de Ciencias de la Ingeniería y Aplicadas; Carrera de Ingeniería Informática y Sistemas Computacionales.
- Ndjiongue, A. R., Ferreira, H. C., & Ngatched, T. M. (1999). Visible light communications (vlc) technology. Wiley Encyclopedia of Electrical and Electronics Engineering, 1-15.
- Ruge Ruge, I. A. (2008). Método básico para implementar un controlador digital pid en un microcontrolador pic para desarrollo de aplicaciones a bajo costo. Apl. en Control Potencia y la Ind.
- Swami, N. V. (2015). Li-Fi (light fidelity) the changing scenario of wireless communication. IJRET: International Journal of Research in Engineering and Technology, 4(3), 435-438.
- Viloria Núñez, C., Cardona Peña, J., & Lozano Garzón, C. (2011). Análisis comparativo de tecnologías inalámbricas para una solución de servicios de telemedicina. Ingeniería y Desarrollo, 25.